

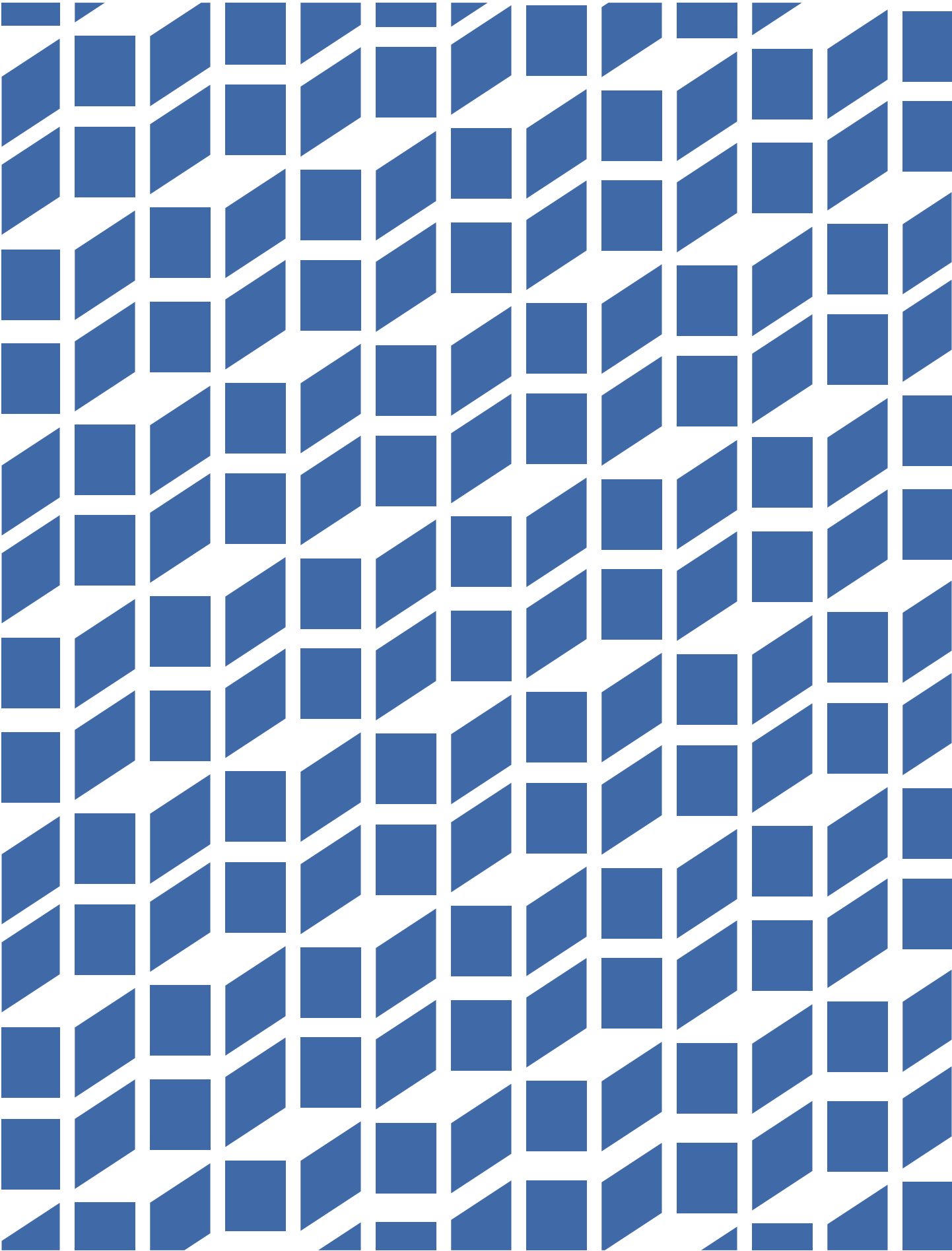

RUBICON™

spaces





INDEX

| | Page |
|-------------------------------------|-------|
| 1. Rubicon Spaces and Grupo Modumex | 2-3 |
| 2. Solid Phenolic Core | 4 |
| 3. Our Hardware | 5 |
| 4. Partition Styles | 6-7 |
| 5. Floor-mounted partitions | 8-9 |
| 6. Overhead Braced Partitions | 10-11 |
| 7. Rubicon LUX | 12-13 |
| 8. Rubicon S2 | 14-15 |
| 9. Urinal Screens | 16-17 |



RUBICON[™]
spaces 

The production process of
Grupo Modumex is



RUBICON™

spaces

With more than 27 years of experience in the manufacturing and construction industry in Mexico and Latin America, Rubicon Spaces comes to life as an effort of Grupo Modumex to expand its commercial operations into the United States. Not only bringing a new option to our customers, but also changing the way we look at public restrooms. Investing not only on quality materials but also durability, aesthetics, privacy and functionality.



GRUPOMODUMEX®





Solid Phenolic Core

1/2" thick compact laminate panels, made from layers of recycled paper fibers dipped in resin stacked and sandwiched between laminate. Later compressed under high pressure and heat to be permanently melted together.

This material is characterized by its aesthetic qualities, durability, and functional performance. It is resistant to wear, impact, scratching, moisture, and heat. It also has good hygienic and anti-static properties. It is easy to clean and maintain, perfect for high-traffic areas. The material will not delaminate even under extreme conditions.

Maintenance and care

- Our partitions can be cleaned with water and regular soap, followed with a cloth to dry it.
- Avoid the use of muriatic acid and bleach or products that may contain it. Do not clean using abrasive fibers or products.
- For grease, paint, graffiti or permanent marker stains, clean with solvent to remove stains, then proceed to rinse with water and soap.

Standard Colors



Standard colors lead time ranges between 2-5 business days plus shipping. A wider variety of colors are available upon request and may require longer delivery times.

Certifications



ISO

Hardware



The best way to ensure durability and functionality on a toilet partition is using high quality hardware. As such, at Grupo Modumex we decided to invest on designing and manufacturing our own hardware. This way, we make sure our hardware not only has the best materials but also is produced under strict procedures that allow us to guarantee them for life.

All of our partitions come with all the hardware needed for proper installation. They also come with a combination coat hook/bumper

Latches

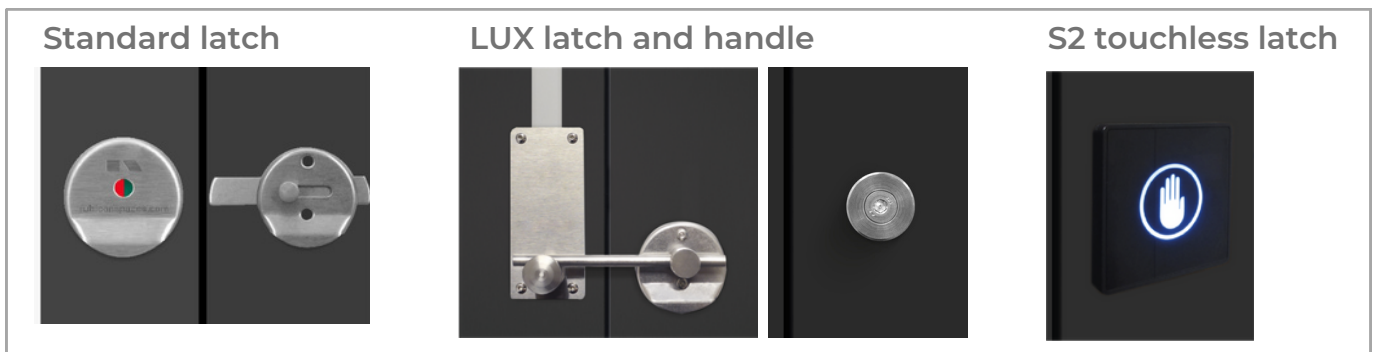

Brackets and Headrail

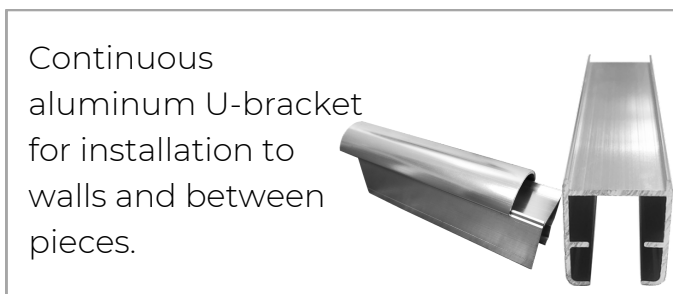

Foot pedestal*

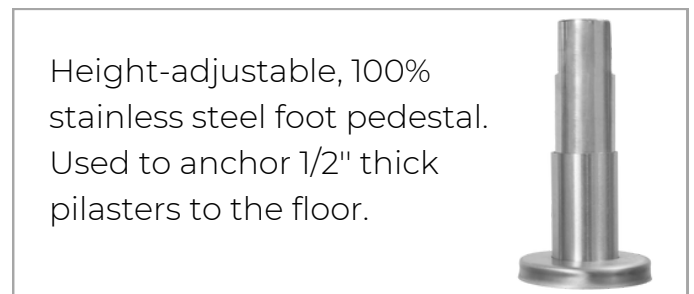

Foot-operated door opener*

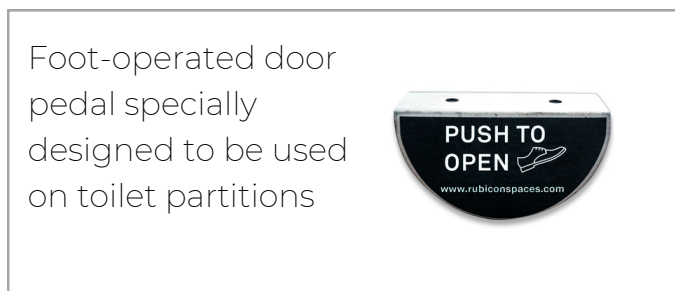

Automatic-close hinge*



***Available for individual sale.**

Partition Styles

Floor mounted Partitions

This style of partition is generally recommended in areas with low ceilings or reduced spaces, that might not be ideal for overhead braced partitions.

The total height of the partition is 71 inches including foot pedestal, with panels and doors being 59 inches tall. To be able to accommodate to different areas, we offer the following widths:

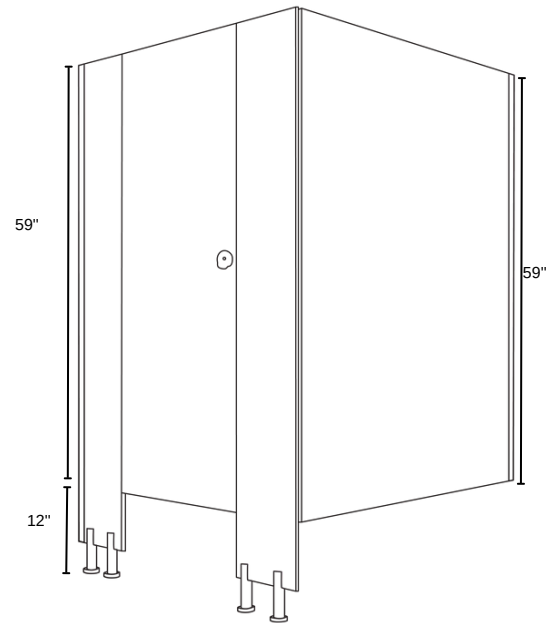

Available widths

| | |
|-----------|--|
| Panels | 22, 24, 26, 28, 30, 32, 34, 36, 40 |
| Pilasters | 4, 5, 6, 7, 8, 10, 12, 14, 16, 18, 20, 22, 24, 34, 36, 40, 48 |
| Doors | 12, 14, 16, 18, 20, 22, 24, 26, 28, 30, 40, 42, 44, 46, 48, 50, 54, 60, 72 |

Overhead Braced Partitions - Including Rubicon Lux and S2

This is the most popular style of partition in the market, perfect for any restroom area. The added overhead brace provide extra strength to the installation and allows for a more aesthetic look when high ceilings are in place.

While maintaining the same size of doors and panels at 59 inches, the height of the pilasters increases to 83 inches including foot pedestal. To be able to accommodate to different projects, we offer the following widths:

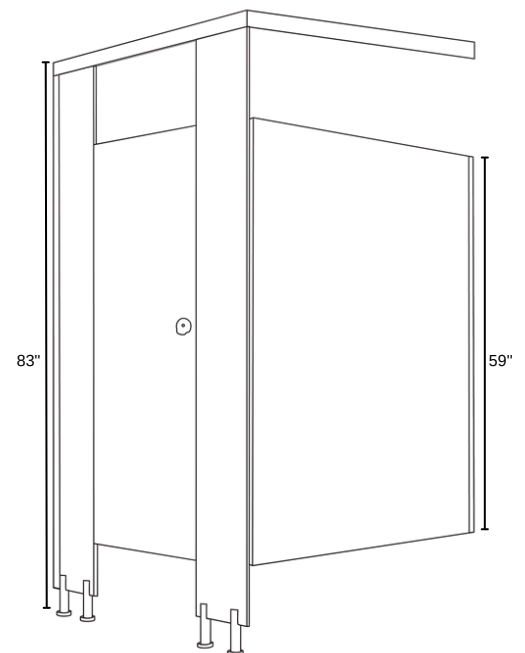

Available widths

| | |
|-----------|--|
| Panels | 22, 24, 26, 28, 30, 32, 34, 36, 40 |
| Pilasters | 4, 5, 6, 7, 8, 10, 12, 14, 16, 18, 20, 22, 24, 34, 36, 40, 48 |
| Doors | 12, 14, 16, 18, 20, 22, 24, 26, 28, 30, 40, 42, 44, 46, 48, 50, 54, 60, 72 |

Floor mounted Partitions



Overhead Braced Partitions



Floor-Mounted Partitions



Floor-Mounted Partitions

Are generally recommended for areas with low ceilings or spaces that might be limited for overhead-braced partitions. This type of partition has all parts of the cubicle with the same height.

All of our pieces are available in a variety of sizes to accommodate the needs of your projects.



Data sheet



Overhead-Braced Floor Mounted Partitions



Overhead-Braced Floor Mounted Partitions

Are the most popular style of partitions. These partitions are floor mounted and stabilized at the top, giving extra strength to the installation and making them the best option for heavy-traffic or vandalism-prone areas.

All of our pieces are available in a variety of sizes to accommodate the needs of your projects.



Data sheet



Rubicon Lux Overhead-Braced Partitions





Occupancy indicator

Latch



Handle

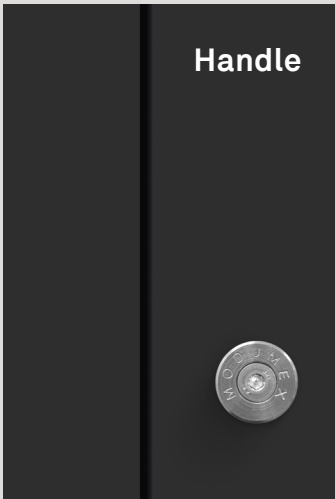

A variation of overhead-braced partitions, Rubicon Lux integrates illuminated occupancy signals that allows users to see if the stall is occupied.

Using the same headrails, we have been able to update our partitions and provide the users with a better experience. Just as the standard overhead-braced model, these partitions are perfect for heavy-traffic areas.

RUBICON S2

Overhead braced partition





Upgrading our overhead-braced partitions and having hygiene as our main concern, we bring Rubicon S2 to the market. Our partition, comes with a sensor-activated latch and a proprietary foot pedal that allows the user to enter and exit the stall without having to touch the door with their hands.

In addition to the touchless experience, our pilasters come with LED occupancy indicator lights.

Data sheet



Urinal Screens



Urinal Screens



General Information

Our urinal screens are constructed of 1/2" thick compact laminate, high-pressure decorative matte surface finish, and black phenolic-core material. The edges are black and finished smooth. They are equipped with stainless-steel hardware and vandal-resistant Torx screws.

Our standard sized screens are 59" tall by 24" in depth, but others sizes are available upon request. They are hung to the wall using our two-ear stainless-steel bracket. Screens are provided with all the hardware and fastenings needed to offer a complete installation.

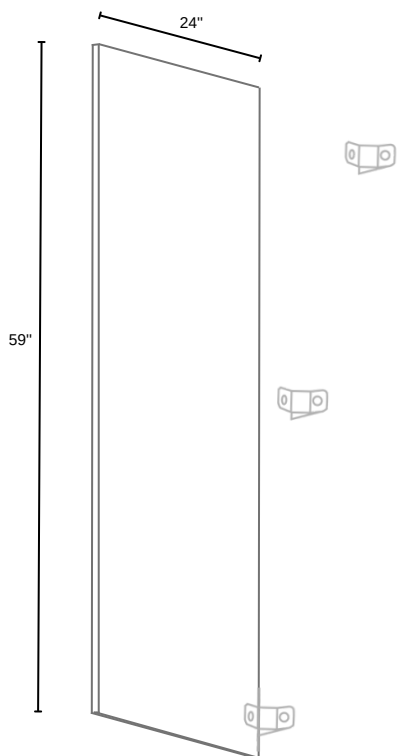

Data sheet



RUBICON™

spaces 



V2/ MARCH
2023